

Assembly Instructions

Savannah

Size Full

sku# 7212-SB-F



394 Dairy Pak Rd. • Athens, GA 30607
kdframes.com • alan@kdframes.com

HARDWARE LIST

H-1	3" BOLT		16
H-3	CROSS DOWEL		24
H-21	2 - 1/2" BOLT		8
H-8	2-1/4" CLEVIS PIN		6
H-5	HAIR PIN		2
H-9	PLASTIC ROLLER		4
H-10	HEX WRENCH		1

PARTS LIST



L-75 STRETCHERS (2)



L-72 BACK RAIL (2)



L-70 SEAT RAIL (2)



L-26 BACK END CAPS (2)



L-27 SEAT END CAPS (2)

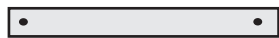

L-24 CONNECTOR SLAT (4)



L-23 REGULAR SLAT (16)

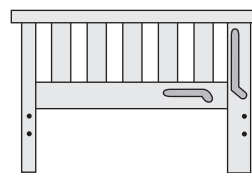

L-1 RIGHT ARM (1)

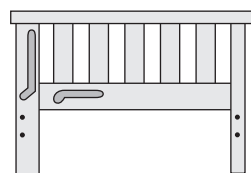

L-2 LEFT ARM (1)

Note: Arms are packed in a separate box.

1 Assemble Back

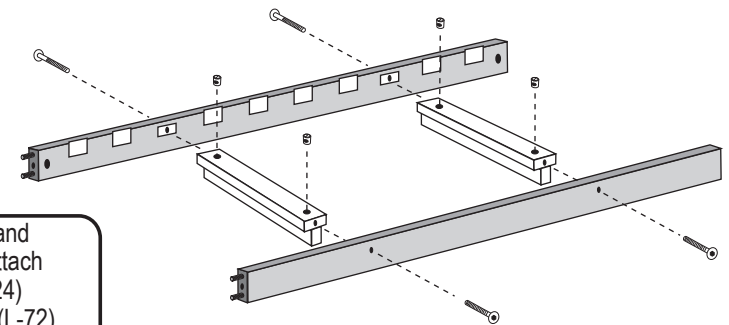

Use 2-1/2" Bolts (H-21) and Cross Dowels (H-3) to attach two Connector Slats (L-24) between the Back Rails (L-72). **Leave the bolts loose.**

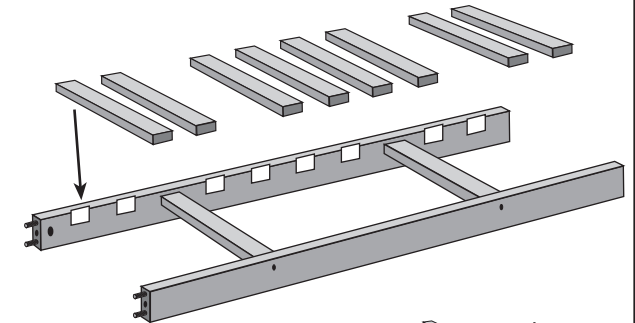

Place (8) Regular Slats (L-23) into the pockets and then tighten the bolts.

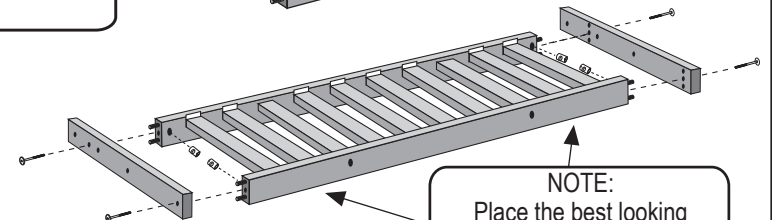

Press the Back End Caps (L-26) onto the wood dowels and attach using 3" Bolts (H-1) and Cross Dowels (H-3).

NOTE: Place the best looking Back Rail on this side to make your frame look its best.

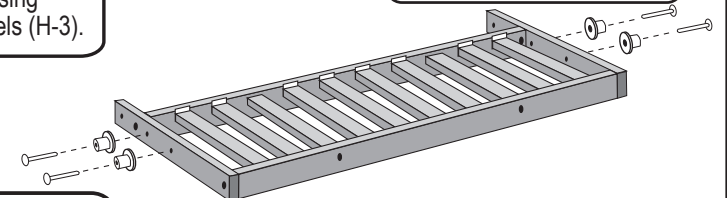

Attach the Plastic Rollers (H-9) by pushing a Clevis Pin (H-8) through the small end of the Roller and into the holes provided in the Back End Caps. (These Clevis Pins do not need hair pins)

2 Assemble Seat

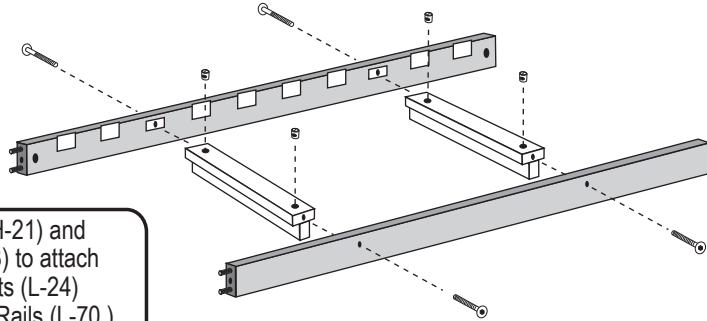

Use 2-1/2" Bolts (H-21) and Cross Dowels (H-3) to attach two Connector Slats (L-24) between the Seat Rails (L-70).
Leave the bolts loose.

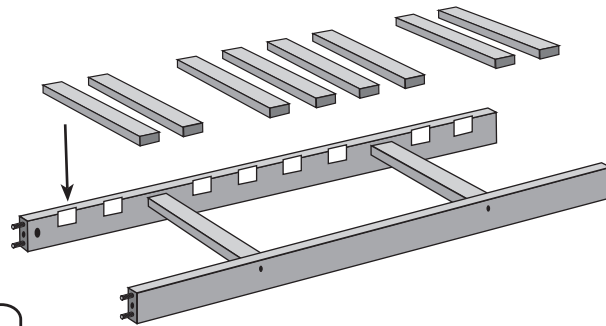

Place (8) Regular Slats (L-23) into the pockets and then tighten the bolts.

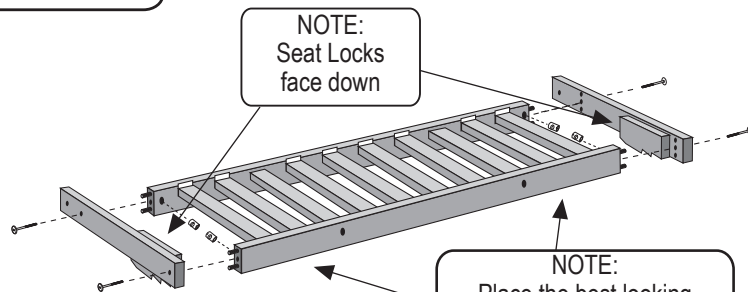

NOTE:
Seat Locks
face down

Make sure that the Seat Locks are facing down as shown and press the Seat End Caps (L-27) onto the wood dowels and attach using 3" Bolts (H-1) and Cross Dowels (H-3).

NOTE:
Place the best looking
Seat Rail on this side
to make your frame look its
best.

3 Assemble Frame

Use 3" Bolts (H-1) and Cross Dowels (H-3) to attach the Stretchers (L-75) to the Arms (L-1 and L-2).
Leave the bolts loose.

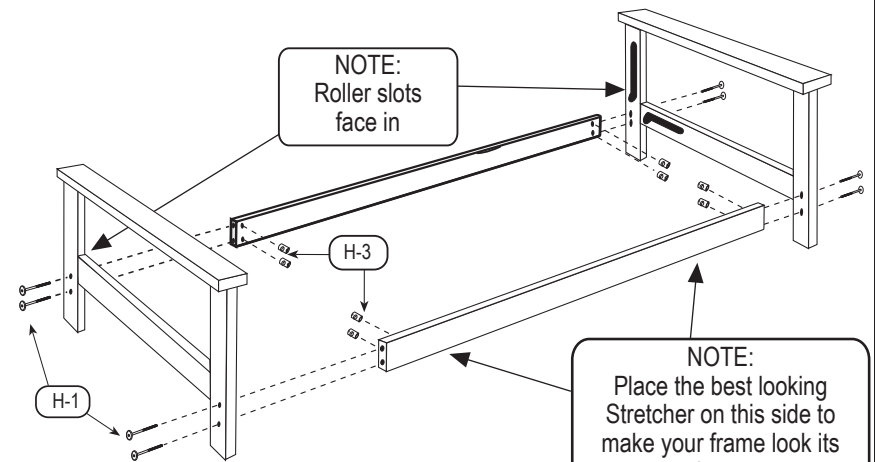

NOTE:
Roller slots
face in

NOTE:
Place the best looking
Stretcher on this side
to make your frame look its
best.

4 Attach Back

Carefully install Back by placing the four Plastic Rollers into the four slots. Make sure that all four Plastic Rollers are in the four different slots, and then tighten the Stretcher Bolts.

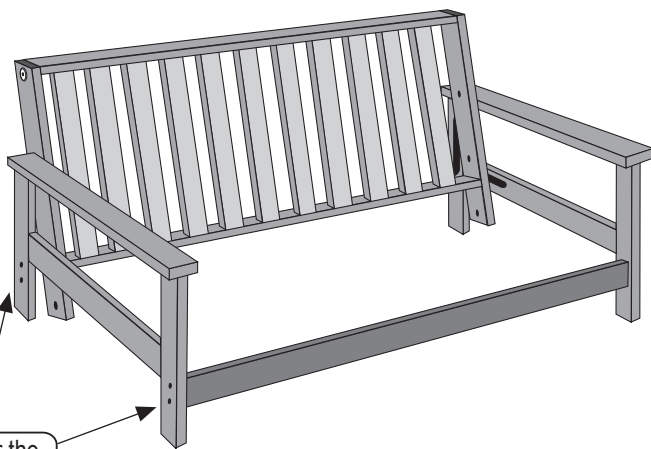
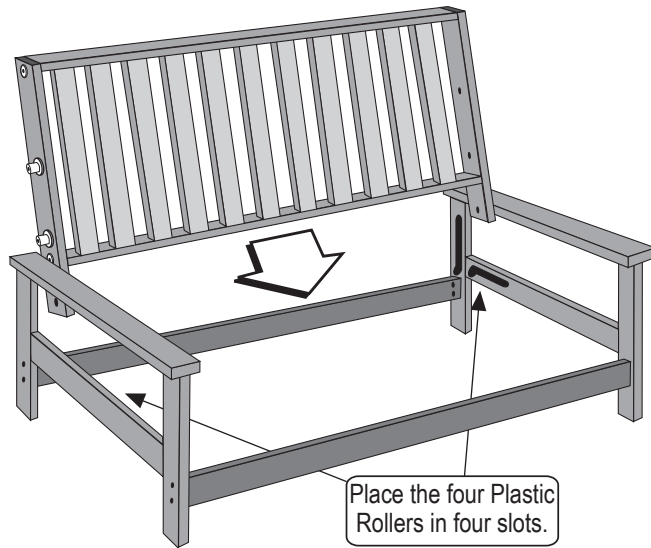

5 Attach Seat

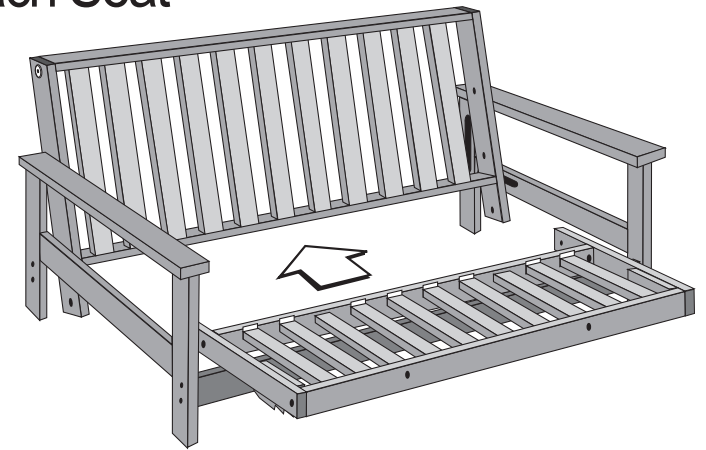

Slide the Seat End Caps in between the Back End Caps. Line up the holes by looking through the hole in the Back End Cap.

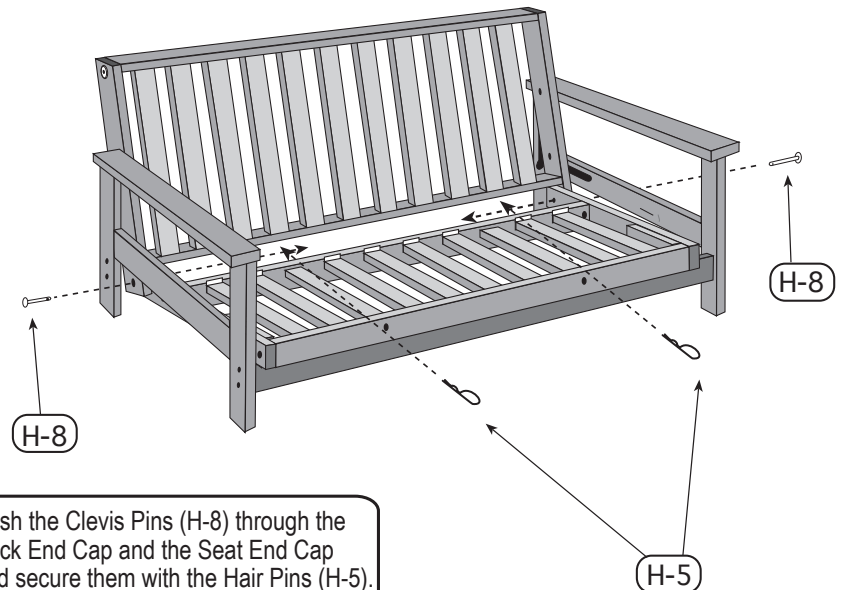

Operation:

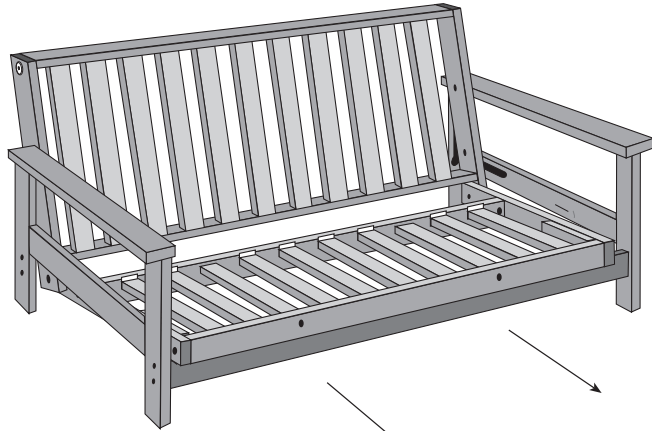

To convert to bed:
Lift up front of Seat to release
Seat lock and gently pull forward.

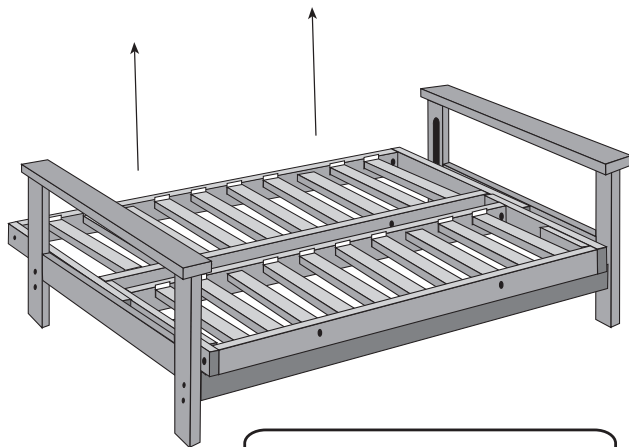

To convert to sofa:
Lift up Back and push forward.

This futon frame is made with Tulip Poplar. Any green tint in the wood will change to light brown in a few weeks. This will happen in 20 to 30 minutes if placed in direct sunlight. Tulip Poplar can be left unfinished, clear finished, stained, or painted. I prefer the lighter stains over the darker ones because the wood is fairly porous. My favorite is a clear finish with no stain. Satin polyurethane (oil or water based) works well.

Painting: It is best to start with an interior primer and lightly sand before painting.

Staining: Lightly sand before staining. Wipe stain on with a rag until you get the desired color. If you are going to use a top coat (such as polyurethane), do not sand again until after the first coat, and then be careful not to sand away the stain.

Finishing: All finishes work well with Tulip Poplar. A simple wax finish over stain (Minwax for example) is easy. An oil finish such as Danish oil can be used. Or a clear top coat such as polyurethane works well to seal the wood. With polyurethanes, the first coat acts as a sanding sealer. So you should lightly sand (180 - 220 grit sandpaper) after the first coat, wipe the wood clean, and then build up coats for the desired effect.

Knockdown Frameworks, Inc. warrants all of its products for five years against any defects that are due to faulty materials or workmanship. We will promptly correct such defects by repair or replacement, at our option, without charge. This warranty covers product defects only and will expire five years after date of purchase by the original consumer purchaser, with proof of purchase required.

This warranty does not apply to damage caused by and resulting from misuse, neglect, accident, or improper operation, maintenance, storage, transportation, or handling of the product. This warranty is for the original consumer purchaser for residential use only and does not apply if the product is used in any commercial application (such as rental property). This warranty does not cover any incidental or consequential damages. If you feel that you have a claim under this warranty, please contact the store from which it was purchased. If this is not possible, call 800-543-3393 for advice on handling your claim.