

Assembly Instructions

FUTON FRAME BIFOLD BODY

Instructions apply to all sizes:
**Chair • Full/Double
 Love seat • Queen**

29A-0007-1

1A Parts in this box.

Chair Size

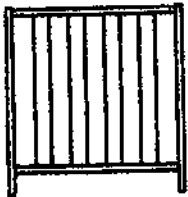

Back Deck (Assembled)



Seat Deck (Assembled)

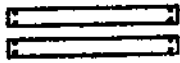

Stretchers
x 2 Pieces

Chair size please note:

The Back Deck and Side Rails are already assembled. Please skip Step 3A.

Full Size



Back Side
Rails x 2

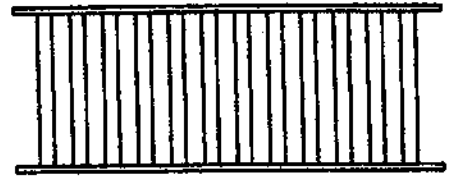

Back Deck

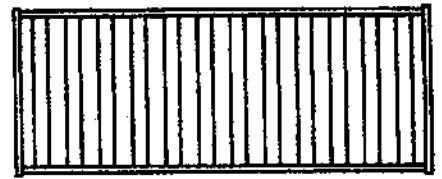

Seat Deck (Assembled)

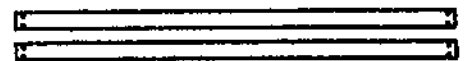

Stretchers x 2 Pieces

Love seat Size



Back Side
Rails x 2

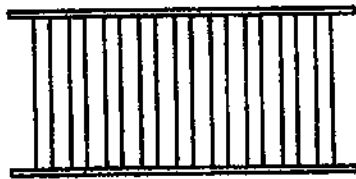

Back Deck

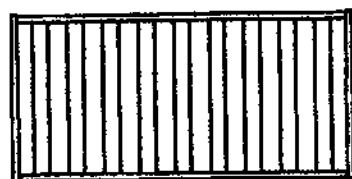

Seat Deck (Assembled)

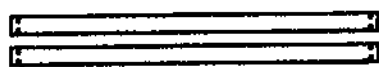

Stretchers x 2 Pieces

Queen Size



Back Side
Rails x 2

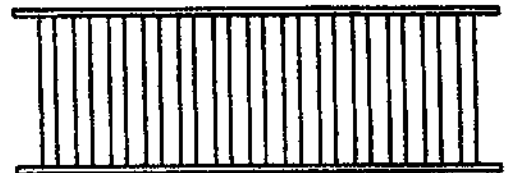

Back Deck

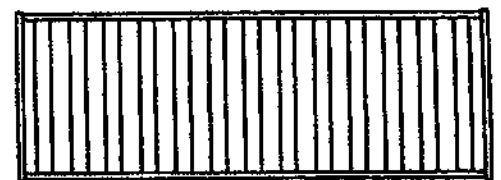

Seat Deck (Assembled)



Short Legs
x 2 Pieces

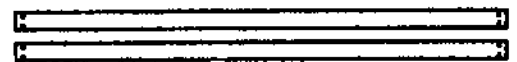

Stretchers x 2 Pieces

1B Hardware in this box.

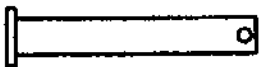

Clevis Pins
x 2 Pieces



Washers
x 2 Pieces



Locking Pins
x 2 Pieces



Wood Button
x 2 Pieces



60mm Bolts x 4 Pieces
For the Side Rails



Barrel Nuts
x 4 Pieces



Wooden Dowel
x 8 Pieces

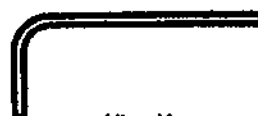

Allen Key
x 1 Piece

Queen size only: Extra hardware



50mm Bolts
x 2 Pieces

Use these bolts to attach the Queen Short Legs to the Seat Deck Side Rails

i Instructions for the Arm assembly, are packed in the Arm box.

2A Prepare Arms for Assembly.

NOTE: The hardware for these steps is included with the Arms. Some Arms may not have these features, so just skip these steps.

Fasten Stretcher Brackets to Arm.

- Insert the Stretcher Bracket Cleat into the hole provided.
- IMPORTANT:** Don't fully tighten Bracket until Stretchers are all in place for easy alignment.
- Each arm requires two brackets, front and back.

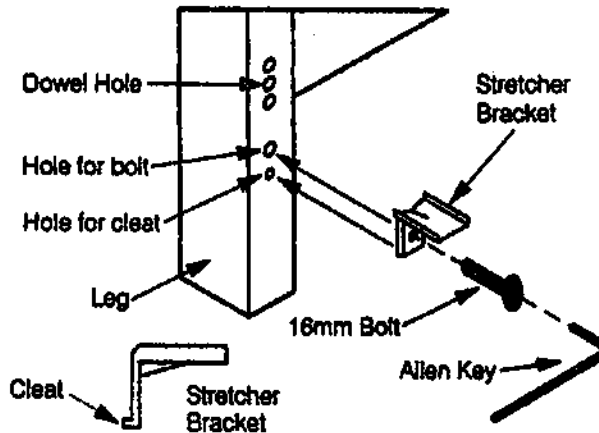

Fit Wooden Dowels.

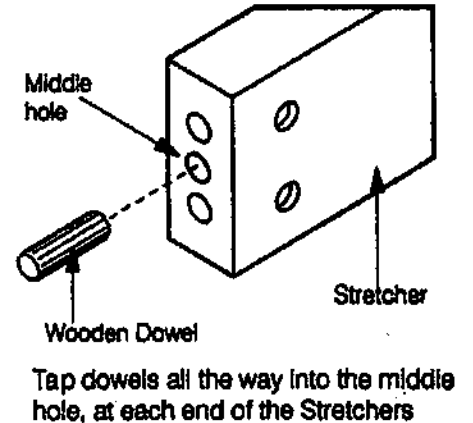

2B Attach Arms to Stretchers.

Your arm style may vary.

Using Bolts and Barrel Nuts provided with the Arms, attach the Arms **LOOSELY** to the Stretchers as shown. It is important that these bolts are left loose!

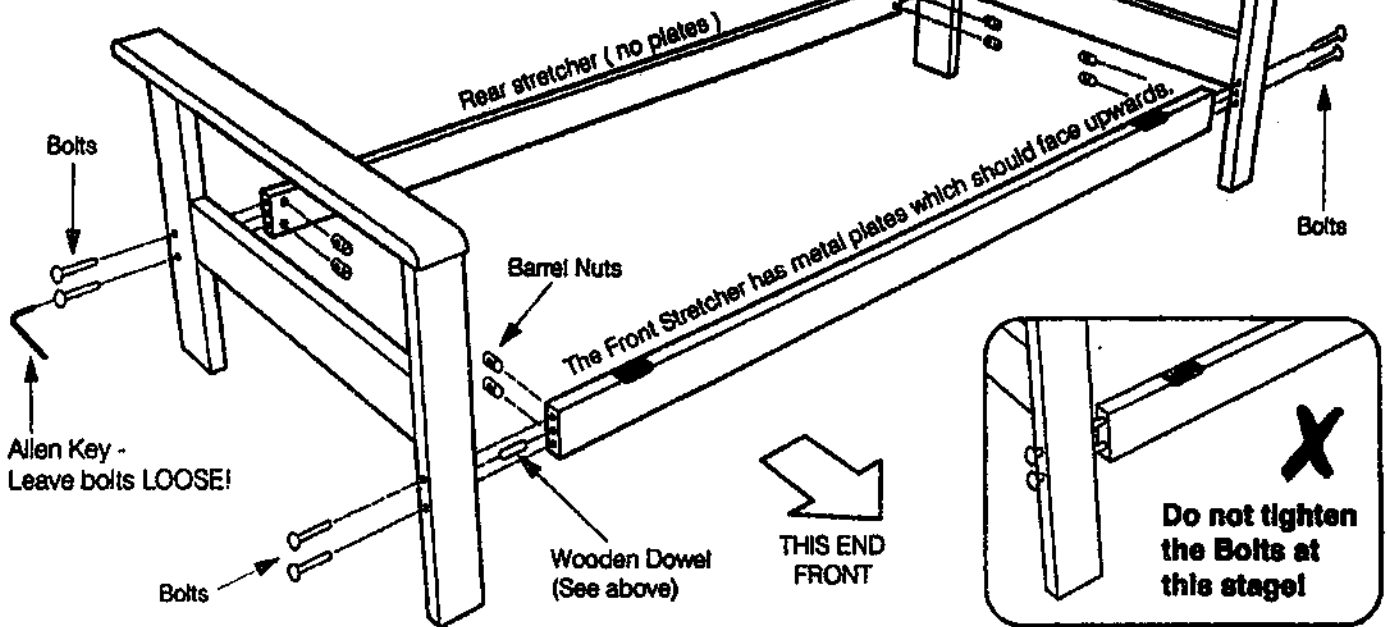

BOLT AND BARREL NUT ASSEMBLY SYSTEM

- ✓ Insert Barrel Nuts as shown using a screwdriver. This will help you position the Nut in line with the Bolt.
- ✓ Do not force the Bolt as you may strip the thread. Be sure the thread is properly started.

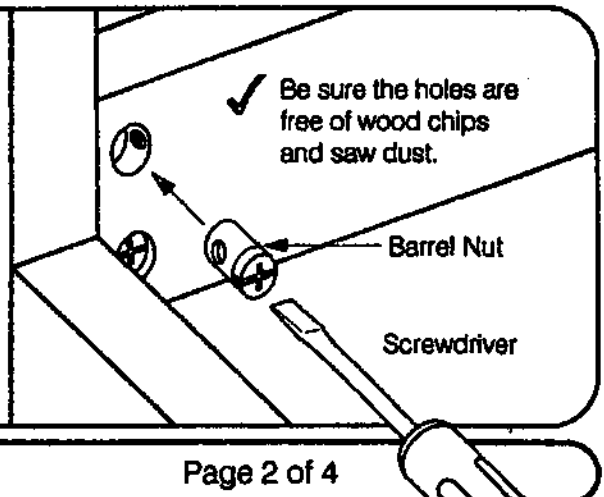
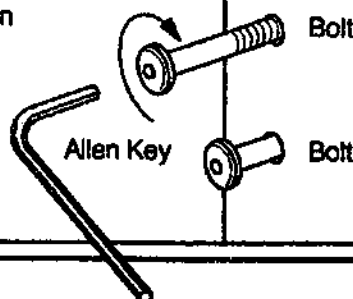

3A Tap the wooden Dowels into the ends of the Back Deck.

Use the Wooden Dowels packed in this box. They fit into the top and bottom holes.

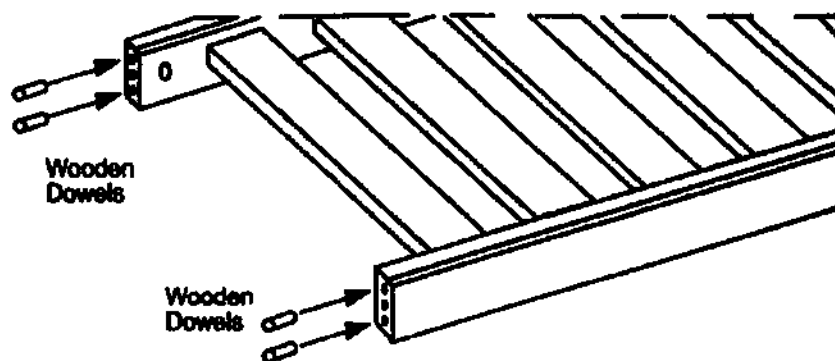

3B Attach the Side Rails to the Back Deck.

Using the Bolts and Barrel Nuts to attach the Side Rails to the Back Deck. Fit Wood Buttons into Bolt holes as shown below.

✓ The Side Rails have a Rounded end, which assembles to the bottom Long Rail.

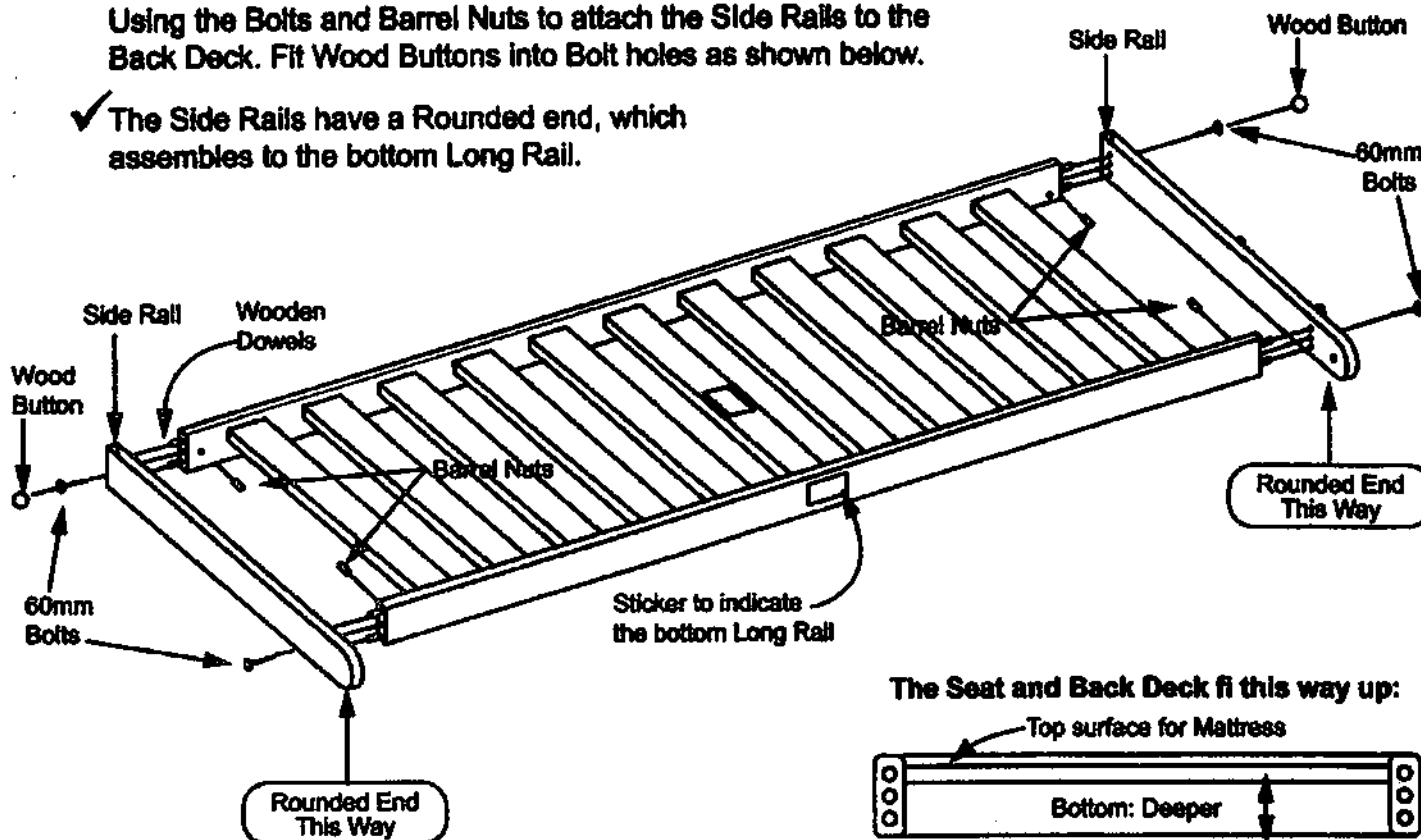

The Seat and Back Deck fit this way up:

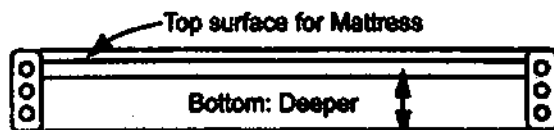

3C Seat Deck: No assembly required

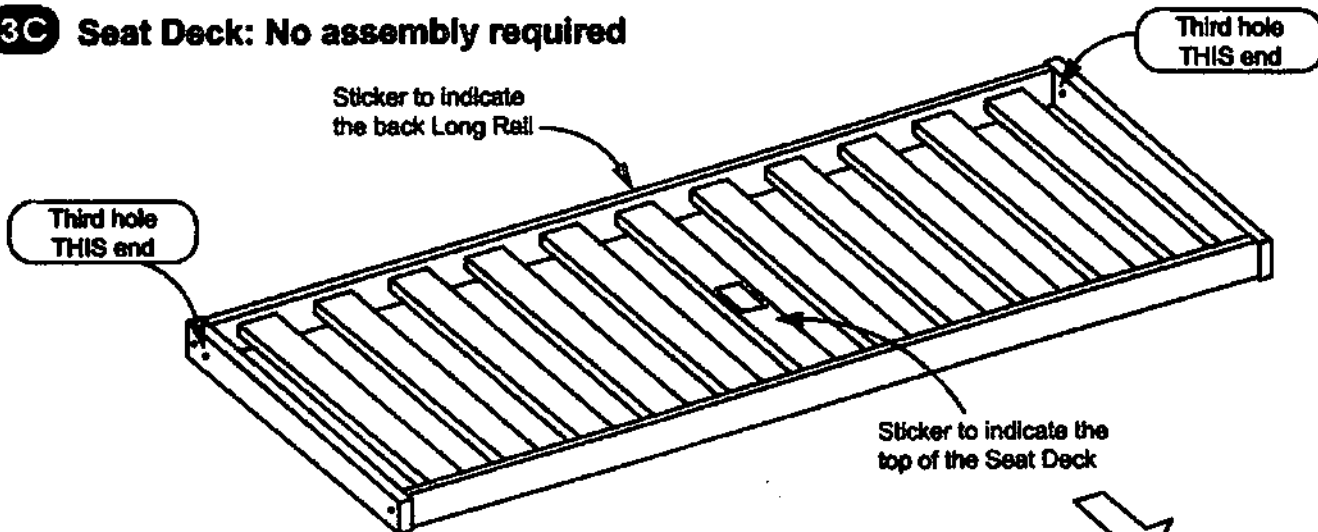

✓ The Seat Deck is already assembled, and no assembly is required.

Front Rail of Seat Deck

4A Fit Back Deck into Position.

Your arm style may vary

- A. Insert the Back Deck lying flat. Insert one end first, then gently lower the other end into position.

- ✓ This step can be tricky - it is best done with two people
- ✓ Remember that the Bolts on the Arm should be LOOSE
- ✗ Be careful not to scratch the Arms with the Plastic Runners when you lower the ends of the Back Deck.

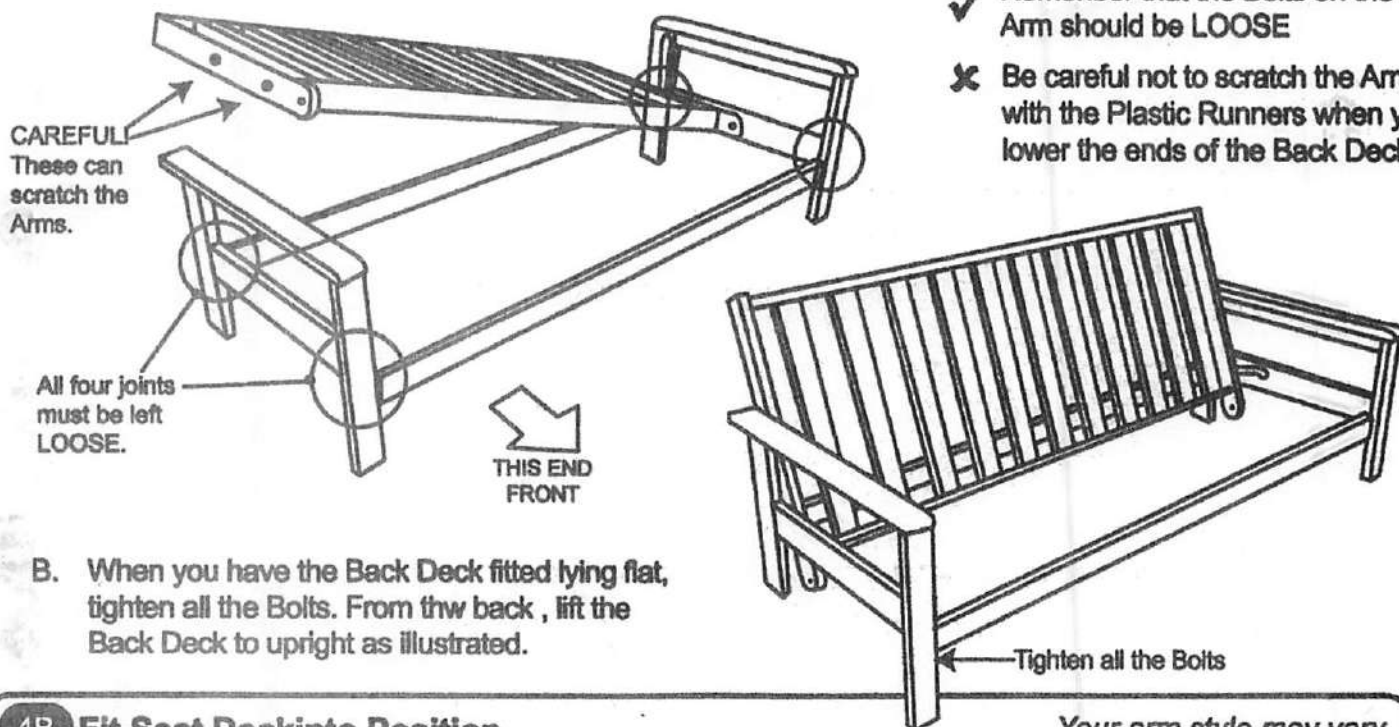

- B. When you have the Back Deck fitted lying flat, tighten all the Bolts. From the back, lift the Back Deck to upright as illustrated.

4B Fit Seat Deck into Position.

Your arm style may vary



Fit the seat deck between the Arms and into the Back Deck as shown. Use the Clevis Pins to connect the two decks. Secure with a Washer and Locking Pin.

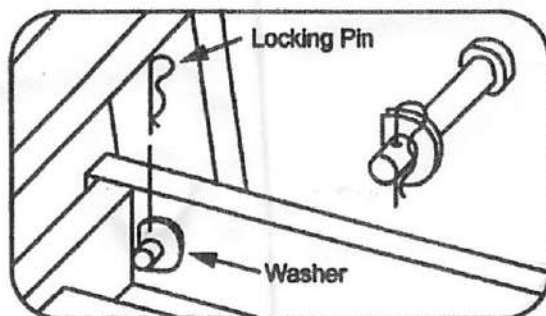

4C For Queen size frame only: Attach short legs

Your arm style may vary

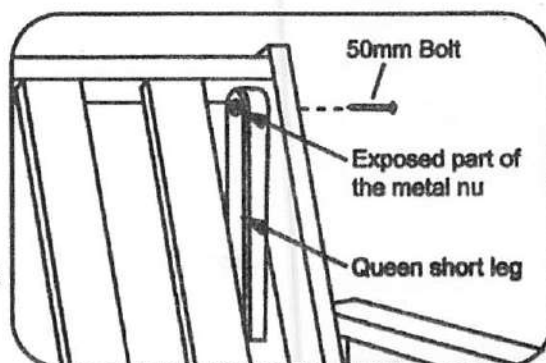
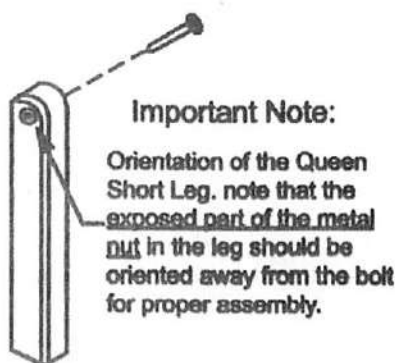
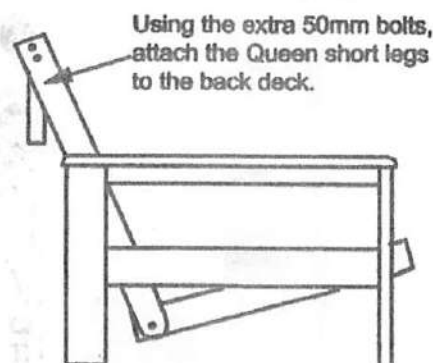

Operating Instructions

FUTON FRAME

This instruction shows Full Body size. Procedure is the same for other sizes.

57A-0381

1 Assembled views

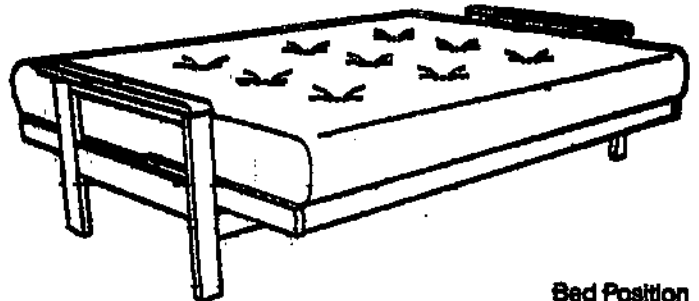
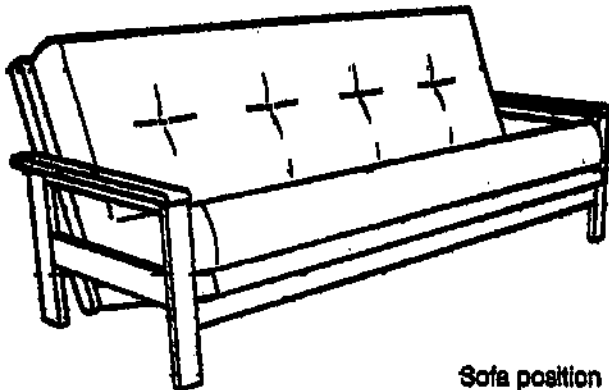

2 Sofa and Lounge to Bed Position

Your arm style may vary.

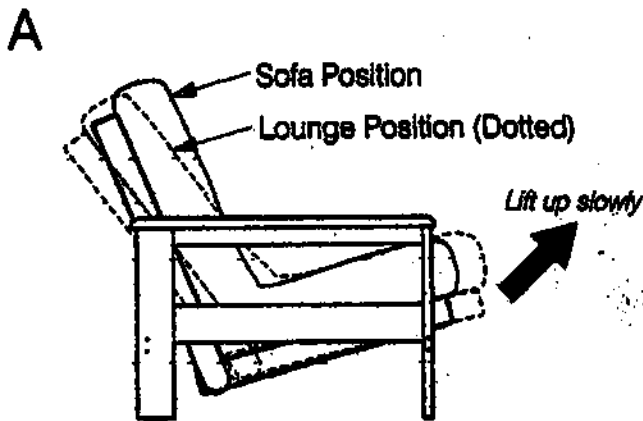

Pull up gently, and let the back drop down slowly.

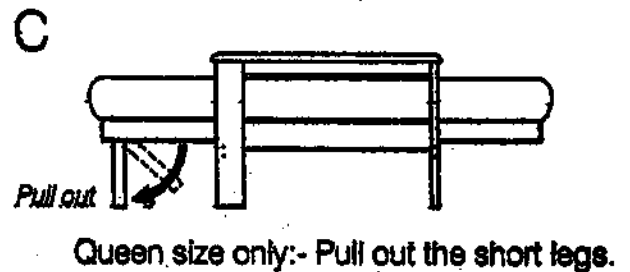
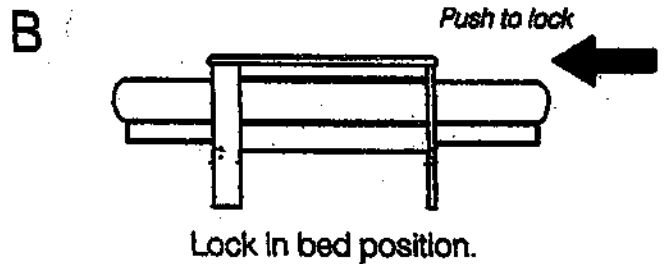

3 Bed to Lounge Position

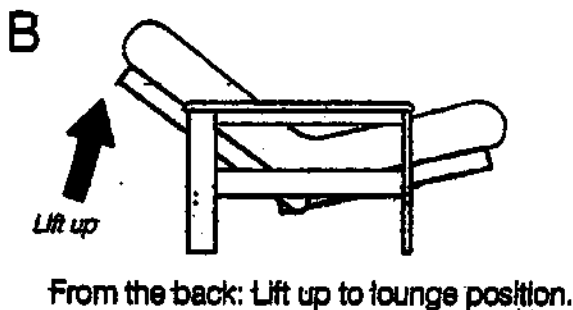
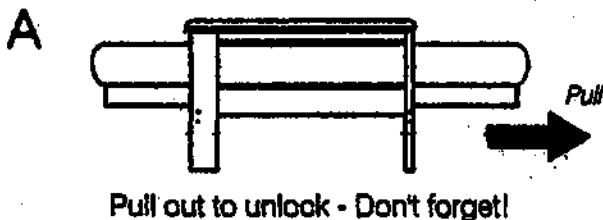

4 Lounge to Sofa Position

