

Assembly Instructions

BIFOLD FUTON FRAME FUTON ARMS

See below for Preparation of arms for assembly.

Winchester-0301

1 One pair of Bifold Arms.

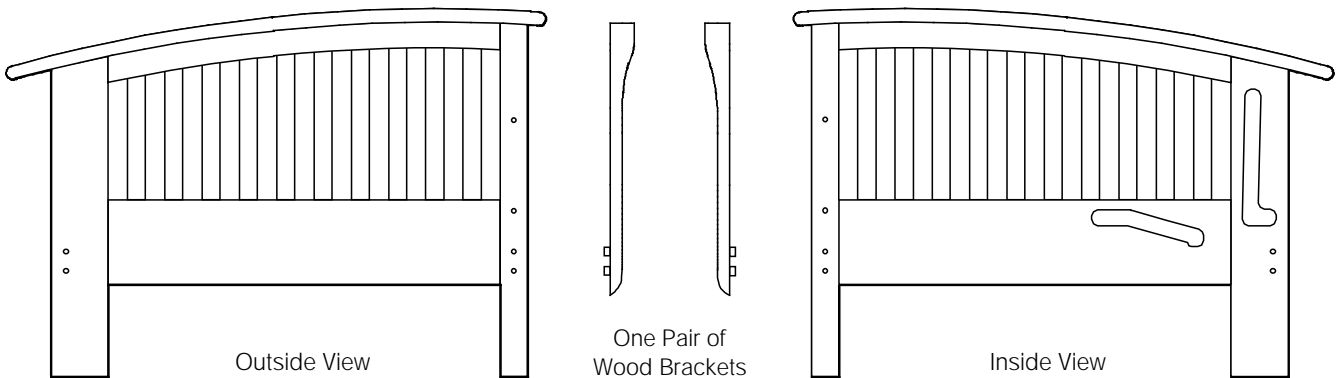

2 Hardware in this box.

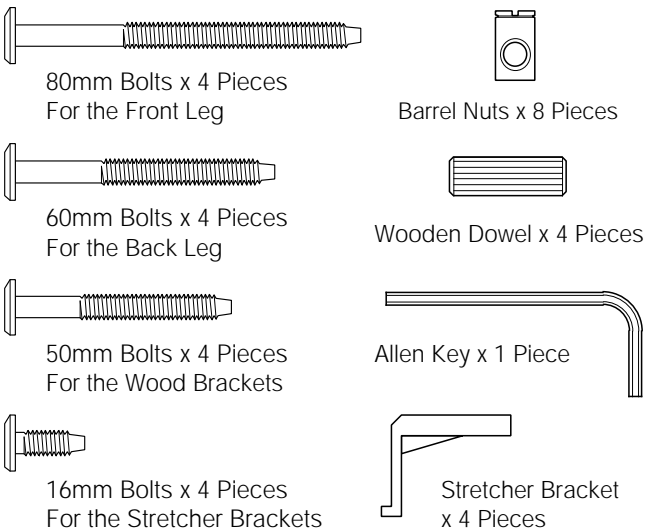

3 Fasten Stretcher Brackets to Arm.

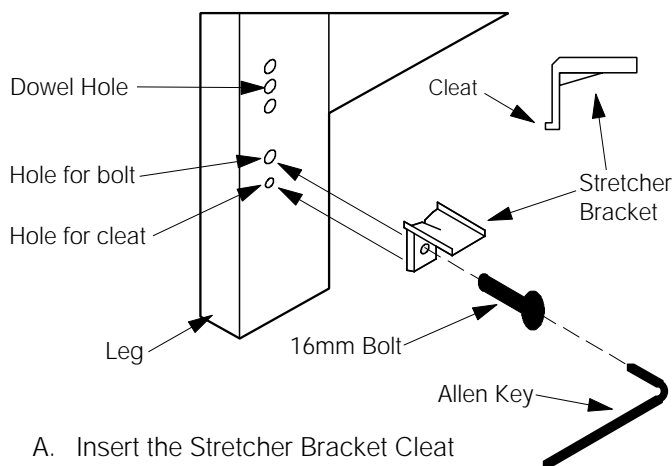

- Insert the Stretcher Bracket Cleat into the hole provided.
- IMPORTANT:** Don't fully tighten Bracket until Stretchers are all in place for easy alignment.
- Each arm requires two brackets, front and back.

4 Assemble the Wood Bifold Body.

BODY INSTRUCTIONS: Instructions for assembly of arms to the Wood Bifold Body are in the BODY box.

- ✓ Use the longer 80mm Bolts to attach the Front Stretcher, the 60mm Bolts on the Back Stretcher.

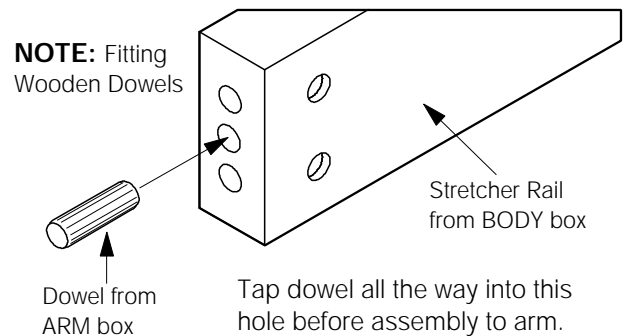

5 Fit Wood Brackets to the Arms.

Only after the Arms and Body have been completely assembled, fix the Wood Brackets to the Arms. Lift the Seat Deck to access the Bolt holes.

- ✓ Before you attach the Wood Brackets, make sure all other Bolts are firmly tightened.

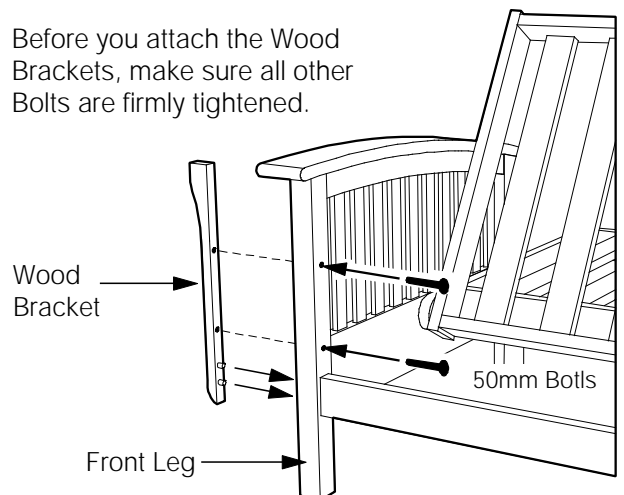

i Instructions for Bifold Body assembly, are packed in the Body box.